

Our associates will ensure the tool works properly before you leave the store. If you experience issues with the tool while completing your project, simply bring it back to the Tool Rental Center to get a replacement. If you purchase Damage Protection at the time of your rental, you are not responsible for repair costs for tools that break due to normal use.





OPERATOR'S MANUAL

**Cat. No.
No de Cat.
6230N
6236N**

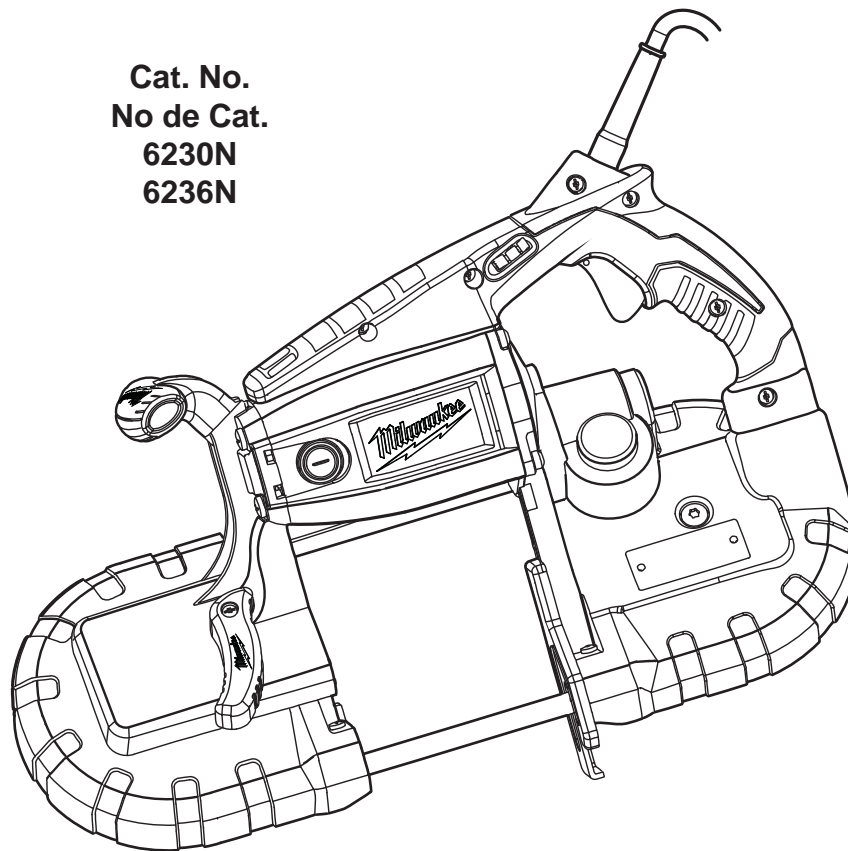

DEEP CUT BAND SAW

TO REDUCE THE RISK OF INJURY, USER MUST READ OPERATOR'S MANUAL.

GENERAL POWER TOOL SAFETY WARNINGS

⚠ WARNING READ ALL SAFETY WARNINGS AND INSTRUCTIONS.

Failure to follow the warnings and instructions may result in electric shock, fire and/or serious injury.

Save all warnings and instructions for future reference

The term "power tool" in the warnings refers to your mains-operated (corded) power tool or battery-operated (cordless) power tool.

WORK AREA SAFETY

- **Keep work area clean and well lit.** Cluttered or dark areas invite accidents.
- **Do not operate power tools in explosive atmospheres, such as in the presence of flammable liquids, gases or dust.** Power tools create sparks which may ignite the dust or fumes.
- **Keep children and bystanders away while operating a power tool.** Distractions can cause you to lose control.

ELECTRICAL SAFETY

- **Power tool plugs must match the outlet. Never modify the plug in any way. Do not use any adapter plugs with earthed (grounded) power tools.** Unmodified plugs and matching outlets will reduce risk of electric shock.
- **Avoid body contact with earthed or grounded surfaces such as pipes, radiators, ranges and refrigerators.** There is an increased risk of electric shock if your body is earthed or grounded.
- **Do not expose power tools to rain or wet conditions.** Water entering a power tool will increase the risk of electric shock.
- **Do not abuse the cord. Never use the cord for carrying, pulling or unplugging the power tool. Keep cord away from heat, oil, sharp edges or moving parts.** Damaged or entangled cords increase the risk of electric shock.
- **When operating a power tool outdoors, use an extension cord suitable for outdoor use.** Use of a cord suitable for outdoor use reduces the risk of electric shock.
- **If operating a power tool in a damp location is unavoidable, use a residual current device (RCD) protected supply.** Use of an RCD reduces the risk of electric shock.

PERSONAL SAFETY

- **Stay alert, watch what you are doing and use common sense when operating a power tool. Do not use a power tool while you are tired or under the influence of drugs, alcohol or medication.** A moment of inattention while operating power tools may result in serious personal injury.

- **Use personal protective equipment. Always wear eye protection.** Protective equipment such as dust mask, non-skid safety shoes, hard hat, or hearing protection used for appropriate conditions will reduce personal injuries.
- **Prevent unintentional starting. Ensure the switch is in the off-position before connecting to power source and/or battery pack, picking up or carrying the tool.** Carrying power tools with your finger on the switch or energising power tools that have the switch on invites accidents.
- **Remove any adjusting key or wrench before turning the power tool on.** A wrench or a key left attached to a rotating part of the power tool may result in personal injury.
- **Do not overreach. Keep proper footing and balance at all times.** This enables better control of the power tool in unexpected situations.
- **Dress properly. Do not wear loose clothing or jewellery. Keep your hair, clothing and gloves away from moving parts.** Loose clothes, jewellery or long hair can be caught in moving parts.
- **If devices are provided for the connection of dust extraction and collection facilities, ensure these are connected and properly used.** Use of dust collection can reduce dust-related hazards.

POWER TOOL USE AND CARE

- **Do not force the power tool. Use the correct power tool for your application.** The correct power tool will do the job better and safer at the rate for which it was designed.
- **Do not use the power tool if the switch does not turn it on and off.** Any power tool that cannot be controlled with the switch is dangerous and must be repaired.
- **Disconnect the plug from the power source and/or the battery pack from the power tool before making any adjustments, changing accessories, or storing power tools.** Such preventive safety measures reduce the risk of starting the power tool accidentally.
- **Store idle power tools out of the reach of children and do not allow persons unfamiliar with the power tool or these instructions to operate the power tool.** Power tools are dangerous in the hands of untrained users.

- **Maintain power tools. Check for misalignment or binding of moving parts, breakage of parts and any other condition that may affect the power tool's operation. If damaged, have the power tool repaired before use.** Many accidents are caused by poorly maintained power tools.
- **Keep cutting tools sharp and clean.** Properly maintained cutting tools with sharp cutting edges are less likely to bind and are easier to control.
- **Use the power tool, accessories and tool bits etc., in accordance with these instructions, taking into account the working conditions and the work to be performed.** Use of the power tool for operations different from those intended could result in a hazardous situation.

SERVICE

- **Have your power tool serviced by a qualified repair person using only identical replacement parts.** This will ensure that the safety of the power tool is maintained.



SPECIFIC SAFETY RULES

- **Hold power tool by insulated gripping surfaces, when performing an operation where the cutting accessory may contact hidden wiring or its own cord.** Cutting accessories contacting a "live" wire may make exposed metal parts of the power tool "live" and could give the operator an electric shock.
- **Maintain labels and nameplates.** These carry important information. If unreadable or missing, contact a *MILWAUKEE* service facility for a free replacement.

- **WARNING:** Some dust created by power sanding, sawing, grinding, drilling, and other construction activities contains chemicals known to cause cancer, birth defects or other reproductive harm. Some examples of these chemicals are:
 - lead from lead-based paint
 - crystalline silica from bricks and cement and other masonry products, and
 - arsenic and chromium from chemically-treated lumber.

Your risk from these exposures varies, depending on how often you do this type of work. To reduce your exposure to these chemicals: work in a well ventilated area, and work with approved safety equipment, such as those dust masks that are specially designed to filter out microscopic particles.

Symbology

FPM	No Load Surface Feet per Minute
	Volts Alternating Current
	Volts Alternating/Direct Current
A	Amps
	Underwriters Laboratories, Inc., United States and Canada

FUNCTIONAL DESCRIPTION

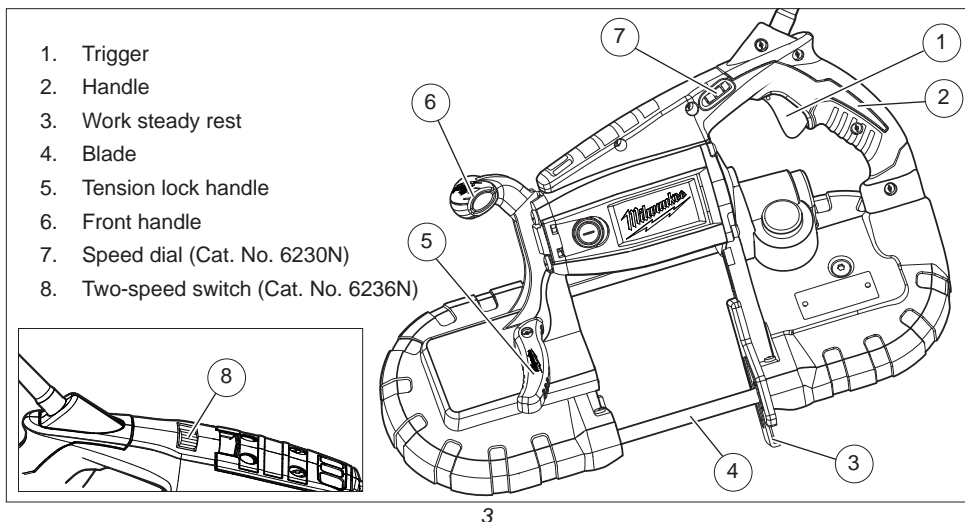

GROUNDING

⚠ WARNING Improperly connecting the grounding wire can result in the risk of electric shock. Check with a qualified electrician if you are in doubt as to whether the outlet is properly grounded. Do not modify the plug provided with the tool. Never remove the grounding prong from the plug. Do not use the tool if the cord or plug is damaged. If damaged, have it repaired by a **MILWAUKEE** service facility before use. If the plug will not fit the outlet, have a proper outlet installed by a qualified electrician.

Grounded Tools: Tools with Three Prong Plugs

Tools marked "Grounding Required" have a three wire cord and three prong grounding plug. The plug must be connected to a properly grounded outlet (See Figure A). If the tool should electrically malfunction or break down, grounding provides a low resistance path to carry electricity away from the user, reducing the risk of electric shock.

The grounding prong in the plug is connected through the green wire inside the cord to the grounding system in the tool. The green wire in the cord must be the only wire connected to the tool's grounding system and must never be attached to an electrically "live" terminal.

Your tool must be plugged into an appropriate outlet, properly installed and grounded in accordance with all codes and ordinances. The plug and outlet should look like those in Figure A.

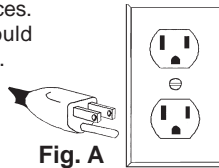

Fig. A

Double Insulated Tools: Tools with Two Prong Plugs

Tools marked "Double Insulated" do not require grounding. They have a special double insulation system which satisfies OSHA requirements and complies with the applicable standards of Underwriters Laboratories, Inc., the Canadian Standard Association and the National Electrical Code. Double Insulated tools may be used in either of the 120 volt outlets shown in Figures B and C.

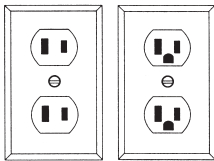

Fig. B

Fig. C

EXTENSION CORDS

Grounded tools require a three wire extension cord. Double insulated tools can use either a two or three wire extension cord. As the distance from the supply outlet increases, you must use a heavier gauge extension cord. Using extension cords with inadequately sized wire causes a serious drop in voltage, resulting in loss of power and possible tool damage. Refer to the table shown to determine the required minimum wire size.

The smaller the gauge number of the wire, the greater the capacity of the cord. For example, a 14 gauge cord can carry a higher current than a 16 gauge cord. When using more than one extension cord to make up the total length, be sure each cord contains at least the minimum wire size required. If you are using one extension cord for more than one tool, add the nameplate amperes and use the sum to determine the required minimum wire size.

Guidelines for Using Extension Cords

- If you are using an extension cord outdoors, be sure it is marked with the suffix "W-A" ("W" in Canada) to indicate that it is acceptable for outdoor use.
- Be sure your extension cord is properly wired and in good electrical condition. Always replace a damaged extension cord or have it repaired by a qualified person before using it.
- Protect your extension cords from sharp objects, excessive heat and damp or wet areas.

Recommended Minimum Wire Gauge for Extension Cords*

Nameplate Amperes	Extension Cord Length				
	25'	50'	75'	100'	150'
0 - 2.0	18	18	18	18	16
2.1 - 3.4	18	18	18	16	14
3.5 - 5.0	18	18	16	14	12
5.1 - 7.0	18	16	14	12	12
7.1 - 12.0	16	14	12	10	
12.1 - 16.0	14	12	10		
16.1 - 20.0	12	10			

* Based on limiting the line voltage drop to five volts at 150% of the rated amperes.

**READ AND SAVE ALL
INSTRUCTIONS FOR
FUTURE USE.**

Specifications

Cat. No.	Tool				Capacities	
	Volts	Amps	FPM	Recommended Blades	Round Stock	Rectangular Stock
6230N	120 AC	10.5	0-420	Bi-Metal	4-3/4"	4-3/4" x 4-3/4"
6236N	120 AC/DC	Lo 5.5 / Hi 10.5	320 / 420	Bi-Metal	4-3/4"	4-3/4" x 4-3/4"

ASSEMBLY

⚠ WARNING To reduce the risk of injury, always unplug tool before attaching or removing accessories or making adjustments. Use only specifically recommended accessories. Others may be hazardous.

Blades and Blade Selection

The blade dimensions required for the band saws are: .020" thickness, 1/2" width and 44-7/8" in length. The special .020" thickness reduces flexure fatigue and provides maximum tooth life. To maximize cutting life, use a blade with the correct pitch (teeth per inch) for the specific cutting job.

Blades are available in several pitches. To select the proper blade, three factors should be considered: The size, shape, and type of material to be cut.

The following suggestions are for selecting the right blade for various cutting operations. Keep in mind that these are broad guidelines and that blade requirements may vary depending upon the specific size, shape and type of material to be cut. Generally, soft materials require coarse pitch blades and hard materials require fine pitch blades. Use coarse pitch blades for thick work and fine pitch blades for thin work. It is important to keep at least three teeth in the cut (see "Typical Application").

Fig. 1

6 Teeth per Inch	• For tough stock 1/2" to 3-3/8" in diameter or width (available in carbon steel only).
8 Teeth per Inch	• For tough stock 3/8" to 1" in diameter or width (available in carbon steel only).
10 Teeth per Inch	• For tough stock 3/16" up to 4-3/4" in diameter or width.
14 Teeth per Inch	• For tough stock 5/32" to 3/4" in diameter or width.
18 Teeth per Inch	• For thin-wall tubing and thin sheets heavier than 21 gauge.
24 Teeth per Inch	• For thin-wall tubing and thin sheets heavier than 21 gauge.

Changing Blades

1. UNPLUG THE TOOL BEFORE REMOVING OR INSTALLING BLADES.
2. Turn the tension lock handle located on the front of the saw 180° counterclockwise. This releases the tension on the blade for easy removal.
3. Remove the blades from the pulley first and then from the guides.
4. To install a new blade, with the pulleys facing up, insert the blade between the rollers and the faces of the guides, making sure that the teeth on the left side of the tool point towards the rear of the tool.
5. With one hand, hold the blade in place between the rollers and the guides and use the other hand to position the blade around the pulleys. Be sure that the blade lies freely within the guard channel before starting the tool motor.
6. Turn the tension lock handle 180° clockwise to lock the position. This will secure the blade on the pulleys.

BE SURE THAT THE BLADE IS PROPERLY SEATED ON THE PULLEYS BEFORE STARTING THE CUT.

Adjusting the Work Steady Rest

To raise or lower the rest, loosen, but do not remove, the two adjusting screws. Slide the rest to the desired position. Tighten the screws securely.

OPERATION

⚠ WARNING To reduce the risk of injury, always unplug tool before attaching or removing accessories or making adjustments. Use only specifically recommended accessories. Others may be hazardous.

⚠ WARNING To reduce the risk of injury, wear safety goggles or glasses with side shields. Keep hands away from the bit and all moving parts.

Two Speed Switch (Cat. No. 6236N)

MILWAUKEE Two-Speed Band Saws are equipped with a speed change switch located on top of the handle. To change speeds, stop the motor and slide the speed change switch to "HI" or "LO" as indicated on the tool. For cutting problem materials, use "LO" speed. Never change from one speed to the other while the motor is running.

Speed Dial (Cat. No. 6230N)

MILWAUKEE Variable Speed Band Saws are equipped with a speed dial located on the side of the handle to set the maximum speed. Rotate the speed dial to "5" for maximum speed, "1" for minimum speed.

Starting and Stopping

1. To **start** the tool, grasp the handles firmly and pull the trigger.
2. To **vary** the speed (Cat. No. 6230N only), increase or decrease pressure on the trigger. The further the trigger is pulled, the greater the speed.
3. To **stop** the tool, release the trigger. Allow the tool to come to a complete stop before removing the blade from a partial cut or laying the tool down.

Typical Application

1. Keep the blade off the workpiece until the motor has reached the selected speed.
2. Start cutting on a surface where the greatest number of teeth will be in contact with the workpiece at one time (Fig 2).
3. Place the work steady rest against the workpiece and lower the moving saw blade into the cut.

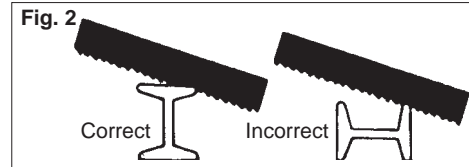

4. Do not bear down while cutting. The weight of the tool will supply adequate pressure for the fastest cutting.
5. When completing a cut, hold the tool firmly so it will not fall against the workpiece (Fig. 3).

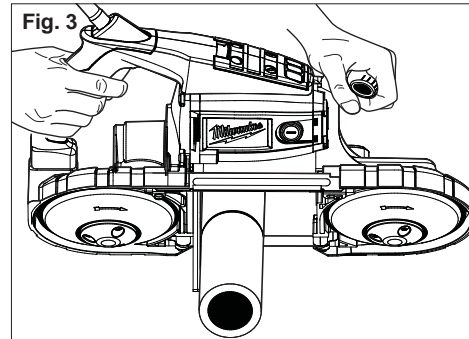

MAINTENANCE

⚠ WARNING To reduce the risk of injury, always unplug your tool before performing any maintenance. Never disassemble the tool or try to do any rewiring on the tool's electrical system. Contact a MILWAUKEE service facility for ALL repairs.

Maintaining Tools

Keep your tool in good repair by adopting a regular maintenance program. Before use, examine the general condition of your tool. Inspect guards, switches, tool cord set and extension cord for damage. Check for loose screws, misalignment, binding of moving parts, improper mounting, broken parts and any other condition that may affect its safe operation. If abnormal noise or vibration occurs, turn the tool off immediately and have the problem corrected before further use. Do not use a damaged tool. Tag damaged tools "DO NOT USE" until repaired (see "Repairs").

Under normal conditions, relubrication is not necessary until the motor brushes need to be replaced. After six months to one year, depending on use, return your tool to the nearest MILWAUKEE service facility for the following:

- Lubrication
- Brush inspection and replacement
- Mechanical inspection and cleaning (gears, spindles, bearings, housing, etc.)
- Electrical inspection (switch, cord, armature, etc.)
- Testing to assure proper mechanical and electrical operation

⚠ WARNING To reduce the risk of injury, electric shock and damage to the tool, never immerse your tool in liquid or allow a liquid to flow inside the tool.

Cleaning

Clean dust and debris from vents. Keep the tool handles clean, dry and free of oil or grease. Use only mild soap and a damp cloth to clean your tool since certain cleaning agents and solvents are harmful to plastics and other insulated parts. Some of these include: gasoline, turpentine, lacquer thinner, paint thinner, chlorinated cleaning solvents, ammonia and household detergents containing ammonia. Never use flammable or combustible solvents around tools.

Repairs

If your tool is damaged, return the entire tool to the nearest service center.

ACCESSORIES

⚠ WARNING To reduce the risk of injury, always unplug the tool before attaching or removing accessories. Use only specifically recommended accessories. Others may be hazardous.

For a complete listing of accessories refer to your MILWAUKEE Electric Tool catalog or go on-line to www.milwaukeetool.com. To obtain a catalog, contact your local distributor or a service center.